

# *Operator's Manual*

**RC6700 / RC6710 / RC6715 / RC6720**

**Air Riveter**



## **WARNING**

*To reduce risk of injury, everyone using, installing, repairing, maintaining, changing accessories on, or working near this tool must read and understand these instructions, as well as separately provided safety instructions part number 8956000414, before performing any such task.*

# Air diagram

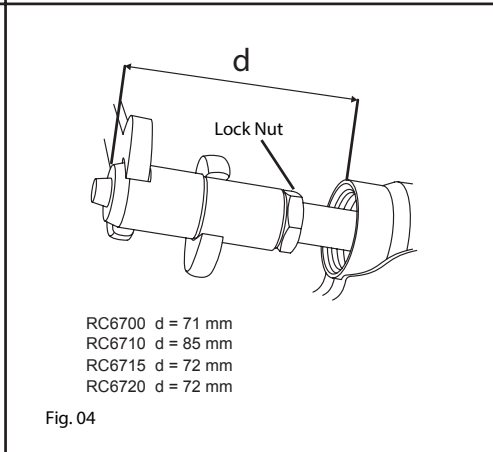
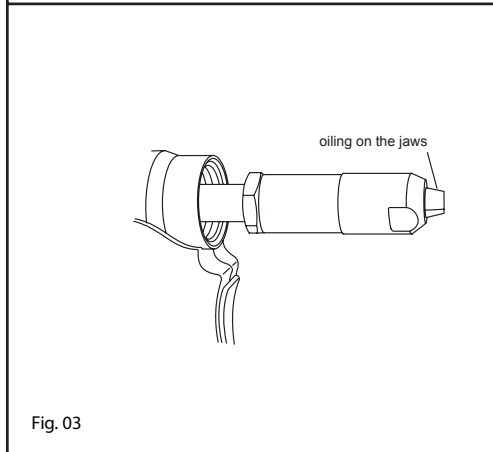
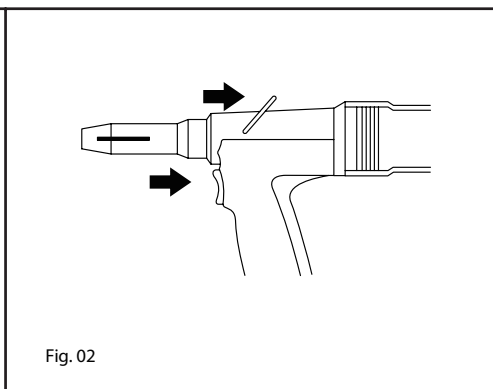
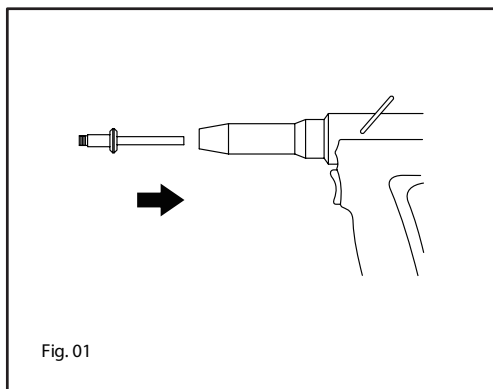
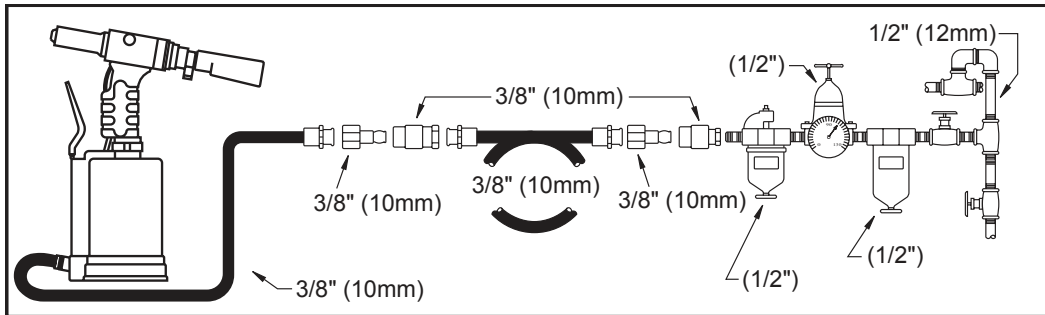

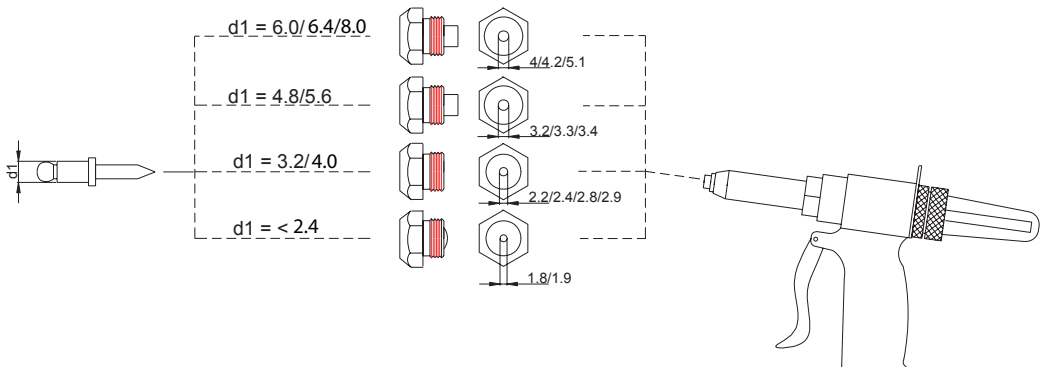

Model	Rivet	Nozzle	Force	Weight	Inner Hose Dia.	Dimension L x W x H	Air Consumption	Air Inlet	Sound pressure $L_{pA}$	Soundpower $L_{wA}$	Vibrations	
			F									
	1	2	3	4	5	6	7	8	9		10	11
	[mm]	[mm]	[N]	[lb] [kg]	[inch] [mm]	[inch] [mm]	[SCFM] [Nl/s]	[inch]	[dB(A)]	[dB(A)]	[m/s <sup>2</sup> ]	[m/s <sup>2</sup> ]
6700	2.4/3.2/4.0/4.8 5.0 Cu, Al	1.8 / 2.2 2.8 / 3.3	12000	3.5 1.6	0.3 8	8.8x11x3.9 225x280x100	0.04 0.02	1/4" IG	86.5	97.5	3.5	0.8
6710	2.4 / 3.2 / 4.0 / 4.8 5.0 / 5.6 / 6.0 / 6.35 6.4 Cu, Al	1.9 / 2.4 2.9 / 3.4 4 / 4.4	19000	4.6 2.1	0.3 8	10x12.8x4.3 255x325x110	0.06 0.03	1/4" IG	64.1	75.1	4.3	0.9
6715	3.2 / 4.0 / 4.8 6.4 Cu, Al, Steel	2.1 / 2.8 3.2 / 4.5	15000	4 1.8	0.3 8	11.8x11.8x3.9 300x300x100	0.038 0.018	1/4" IG	77.3	88.3	2.4	0.7
6720	5 / 6 / 6.4 / 8mm 6.4 MonoBolt Cu, Al, Steel	3.2 / 4.3 / 5.1 / 4.2	17000	5.7 2.6	0.3 8	11.8x12.2x1.8 300x310x122	0.07 0.03	1/4" IG	66.2	77.2	3.5	0.8

IG = Innengewinde / female thread

AG = Außengewinde / male thread

Cu, Al: Only for rivets made from copper, Aluminium or softer material

Steel: also for rivets made from Steel or softer Material,

INOX: also for rivets made from stainless Steel



1. Technical Data

Model	Rivet	Nozzle	Force	Weight	Inner Hose Dia.	Dimension L x W x H	Air Consumption	Air Inlet	Sound pressure L <sub>PA</sub>	Sound power L <sub>WA</sub>	Vibrations	
				lb/kg							a <sub>hd</sub>	k
			F									
	1	2	3	4	5	6	7	8	9		10	11
	[mm]	[mm]	[N]	[lb] [kg]	[inch] [mm]	[inch.] [mm]	[NI/s]	[mm]	[dB(A)]	[dB(A)]	[m/s <sup>2</sup> ]	[m/s <sup>2</sup> ]

max. pressure 6.3bar(90psi)

a<sub>1</sub> : Blows per minute, k Uncertainty ; L<sub>WA</sub> Sound pressure dB(A), K<sub>PA</sub> = K<sub>WA</sub> = 3 dB Uncertainty .

Declaration of noise and vibration statement (ISO 15744 and ISO 20643)

These declared values were obtained by laboratory type testing in accordance with the stated standards and are suitable for comparison with the declared values of other tools tested in accordance with the same standards. These declared values are not adequate for use in risk assessments and values measured in individual work places may be higher. The actual exposure values and risk of harm experienced by an individual user are unique and depend upon the way the user works, the workpiece and the workstation design, as well upon the exposure time and the physical condition of the user. We, RODCRAFT PNEUMATIC TOOLS, cannot be held liable for the consequences of using the declared values, instead of values reflecting the actual exposure, in an individual risk assessment in a work place situation over which we have no control. This tool may cause hand-arm vibration syndrome if its use is not adequately managed. An EU guide to managing hand-arm vibration can be found at [www.pneurop.eu/uploads/documents/pdf/PN3-02-NV\\_Declaration\\_info\\_sheet\\_0111.pdf](http://www.pneurop.eu/uploads/documents/pdf/PN3-02-NV_Declaration_info_sheet_0111.pdf). We recommend a programme of health surveillance to detect early symptoms which may relate to noise or vibration exposure, so that management procedures can be modified to help prevent future impairment.

2. Machine type(s)

- This rivet gun is designed for inserting rivets into all materials.No other use permitted. For professional use only.
- Please read the instructions carefully before starting the machine.

3. Mounting instruction

- Always mount rivet seat corresponding to selected rivets. Ensure the use of correct chuck jaws according to rivet size, as described in Fig. 01. The appropriate tools are supplied; please see details under "Maintenance".
- Insert the blind rivet into the rivet seat, as shown in Fig. 01.
- Press the trigger (Fig. 02) to pull the rivet (wear eye protection).

4. Lubrication

- Use an air line lubricator with SAE #10 oil, adjusted to two drops per minute. If an air line lubricator cannot be used, add air motor oil to the inlet once a day.
- Apply one drop of machine oil to the chuck jaws every 5,000 cycles (Fig. 03).

5. Maintenance instruction

- Keep the tool clean and away from aggressive chemicals. Do not leave the tool outdoors.
- Unscrew the casing head with jaw spanner SW 24. Clean chuck jaws, chuck jaw seats and casing head. Lubricate the chuck jaws (Fig. 03). Assemble casing head in opposite sequence (do not overtighten casing head).
- Use jaw spanners SW 17 and SW 15 to unscrew or replace chuck jaws or chuck jaw seats. Remove old chuck jaw from chuck jaw seat and replace (Fig. 04).

**Do not loosen or remove the lock nut! The distance of 71/72/85mm between the tip of the chuck jaw and the casing must be kept, as shown in Fig. 04. Damages due to noncompliance are excluded from the warranty.**

- A complete oil change is not necessary! Check and fill up hydraulic oil level if after approximately 100,000 cycles the travel decreases or a blind rivet is not completely pulled. Observe the safety precautions.

**Only use hydraulic oil (ISO VG22) approved by the manufacturer. Please note: Never use brake fluid.**

- To keep downtime to a minimum, the following service kits are recommended :

Tune-up kit : see part list

6. Disposal

- The disposal of this equipment must follow the legislation of the respective country.
- All damaged, badly worn or improperly functioning devices MUST BE TAKEN OUT OF OPERATION.
- Repair only by technical maintenance staff.

7. Declaration of conformity

We : Rodcraft Customer Center - Langemarckstr.35 bis 45141 Essen- Germany

Machine type(s) : Air riveter

Declare that the product(s) : RC6700 / RC6710 / RC6715 / RC6720

Serial Number : 001 - 999

Origin of the product : TAIWAN

is in conformity with the requirements of the council Directives on the approximation of the laws of the Member States relating : to "Machinery" 2006/42/EC (17/05/2006) applicable harmonised standard(s) : EN ISO 11148-1:2011

Name and position of issuer : Pascal Roussy (R&D Manager)

Place & Date : Saint-Herblain, 10/07/2015

Technical file available from EU headquarter. Pascal Roussy R&D manager CP Technocenter 38, rue Bobby Sands - BP10273 44800 Saint Herblain - France

Copyright 2015, RODCRAFT

All rights reserved. Any unauthorized use or copying of the contents or part thereof is prohibited. This applies in particular to trademarks, model denominations, part numbers and drawings. Use only authorized parts. Any damage or malfunction caused by the use of unauthorized parts is not covered by Warranty or Product Liability.

Original Instructions